

FREEDOM QUILT CODE PATTERNS

FLYING GEESE — *Slaves saw that geese flew north every spring. The Flying Geese pattern said follow the direction of the geese and you will be going north – to Canada and freedom. The two darkest triangles in the quilt pointed the direction to follow. The quilt had to be carefully placed so the direction was correct.*

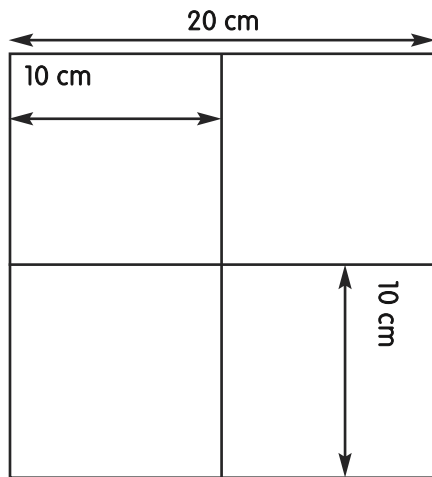

1. Draw a square 20 cm x 20 cm.
2. Draw lines parallel to the sides of the square to divide it into quarters.

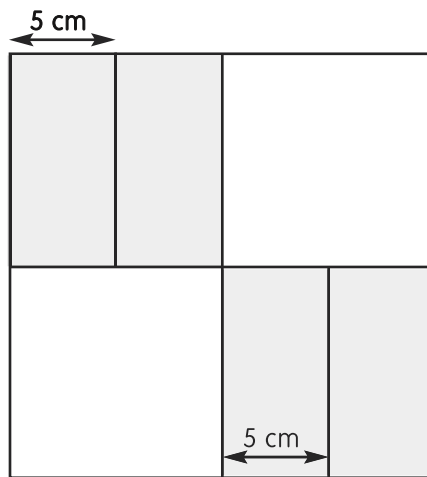

1. In the top LEFT quadrant draw a line parallel to the SIDE of the square to divide the quadrant in half.
2. Repeat in the bottom, RIGHT quadrant.

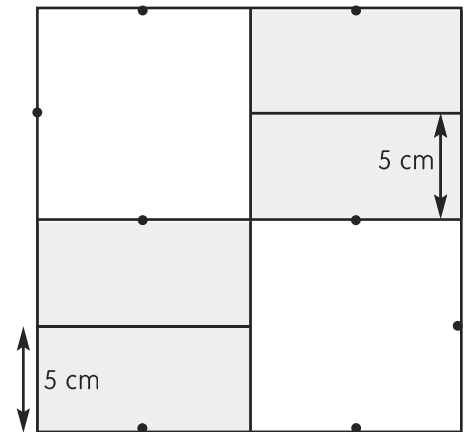

1. In the bottom LEFT quadrant draw a line parallel to the BOTTOM of the square to divide the quadrant in half.
2. Repeat in the top, RIGHT quadrant.
3. Mark the midpoint on all 4 sides of each quadrant.

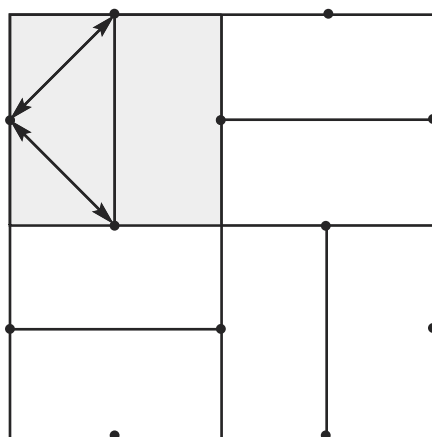

1. Work in the top LEFT quadrant.
2. Draw diagonal lines from the midpoint on the SIDE of the quadrant to the ends of the vertical line in that quadrant.

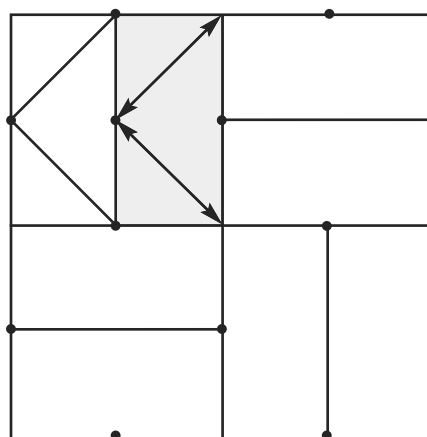

1. Mark the midpoint on the vertical line in the quadrant.
2. Draw diagonal lines from the midpoint to the ends of the side of the quadrant.

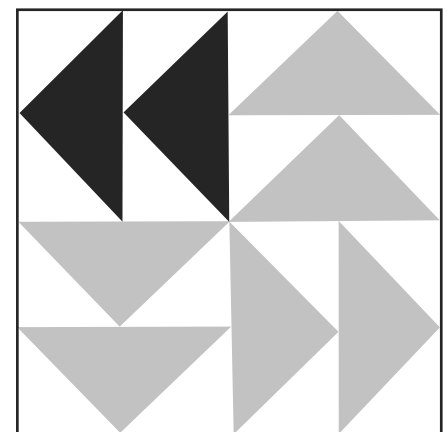

1. Repeat this process in each quadrant to make a total of 8 triangles.
2. Colour the triangles as shown.
3. Remember to colour the triangles in one quadrant darker than the others.

FREEDOM QUILT CODE PATTERNS

BOW TIE — *In the northern states free blacks wore a coat and a shirt with a bow tie. The bow tie pattern was a message to escaping men to dress up and wear a cotton shirt with a silk bow tie so they would look like freemen.*

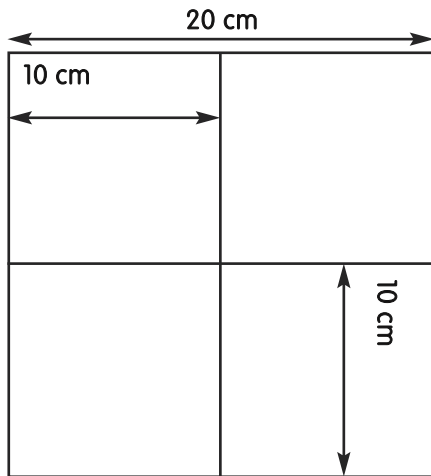

1. Draw a square 20 cm x 20 cm.
2. Draw lines parallel to the sides of the square to divide it into quarters.

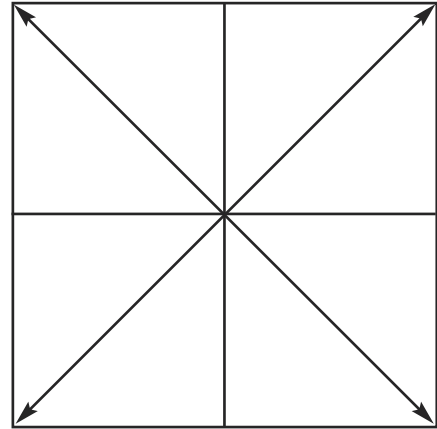

1. Draw a diagonal line from one corner to the opposite corner.
2. Repeat for the other corner to form a large X.

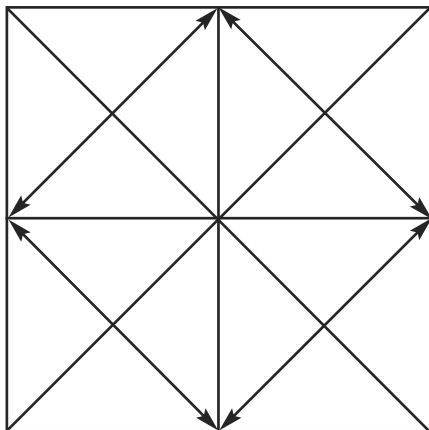

1. Draw a diagonal line from the 10 cm point at the top of the square to the 10 cm point on the side of the square.
2. Repeat for each side of the square.

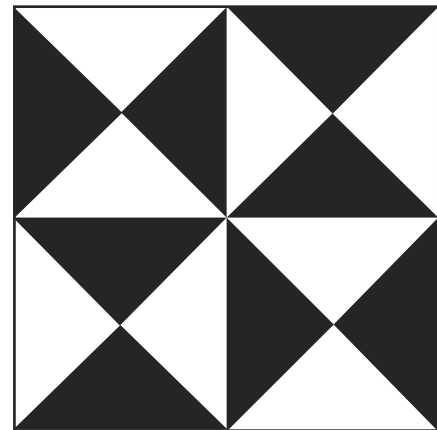

1. Colour the triangles as shown.

FREEDOM QUILT CODE PATTERNS

NORTH STAR — *The North Star is easy to see on a clear night. The North Star pattern told slaves to follow the star because it would lead them to Canada and freedom. It was also the code name for a station on the Underground Railway operated by Reverend John Rankin in Ripley, Ohio.*

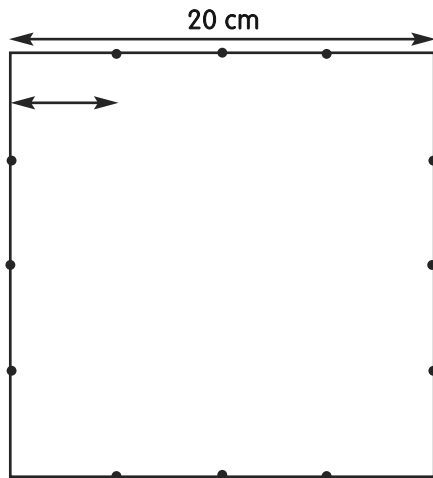

1. Draw a square 20 cm x 20 cm.
2. Divide each side into 5 cm intervals and mark the spots.

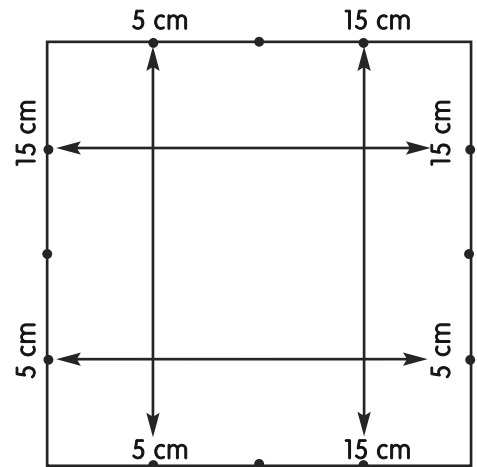

1. Draw vertical lines to connect the TOP 5 cm and 15 cm marks with the opposite 5 cm marks.
2. Draw horizontal lines to connect the SIDE 5 cm and 15 cm marks with the opposite 5 cm and 15 cm marks.

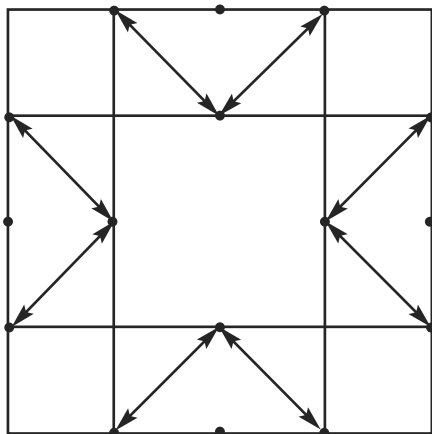

1. Find and mark the midpoint on each side of the small square in the middle of the 20 cm square.
2. Draw vertical lines from the 5 cm and 15 cm marks to the midpoint mark on each side of the square.

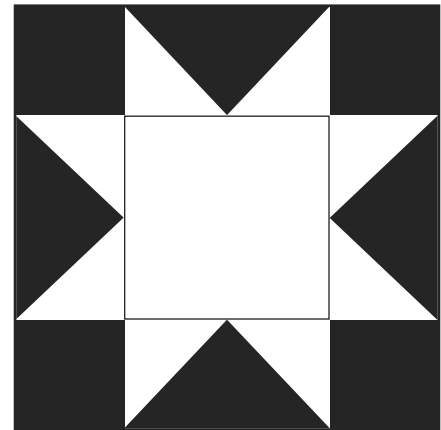

1. Colour as shown.

FREEDOM QUILT CODE PATTERNS

CROSSROADS — *The Crossroads was a pattern woven into fabric in many parts of Africa. It represents times when you had to make an important decision. In the Quilt Code it meant Cleveland, Ohio. It was in Cleveland that escaping slaves had to decide once and for all to leave everything behind and cross Lake Erie into Canada.*

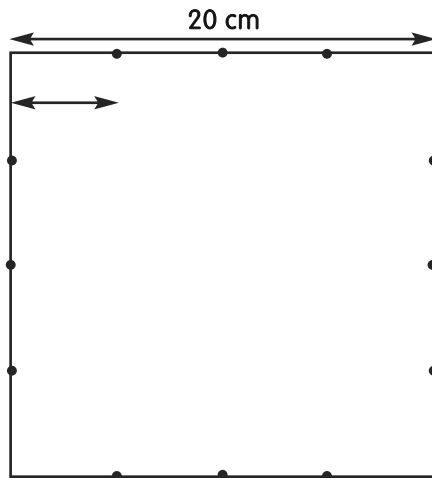

1. Draw a square 20 cm x 20 cm.
2. Divide each side into 5 cm intervals and mark the spots.

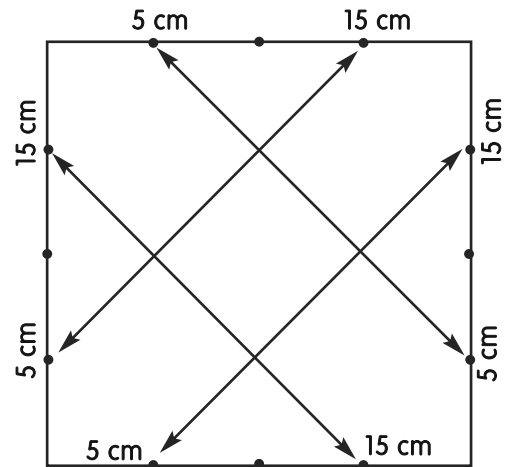

1. Draw diagonal lines to connect the TOP 5 cm and 15 cm marks with the opposite 5 cm marks.
2. Draw diagonal lines to connect the SIDE 5 cm and 15 cm marks with the opposite 5 cm and 15 cm marks.

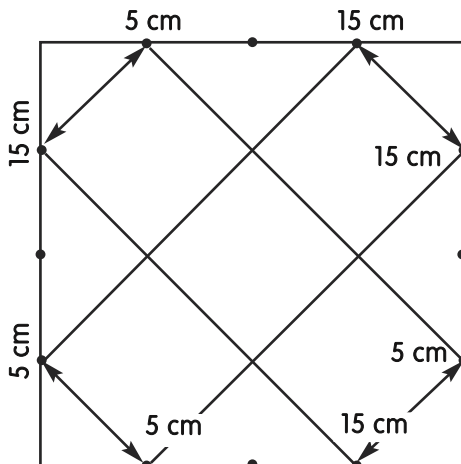

1. Draw diagonal lines to connect the marks in each corner of the square as shown.

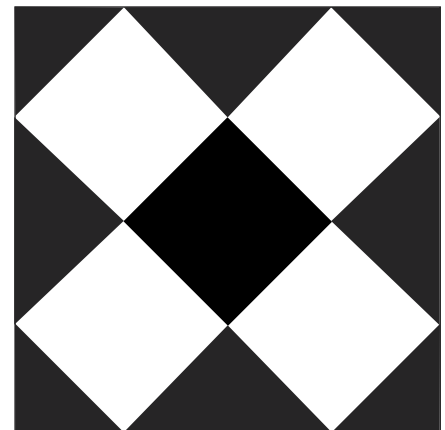

1. Colour as shown.